

THI – 1500 series
Brake cam Tube enclosures for Hendrickson INTRAAX suspensions

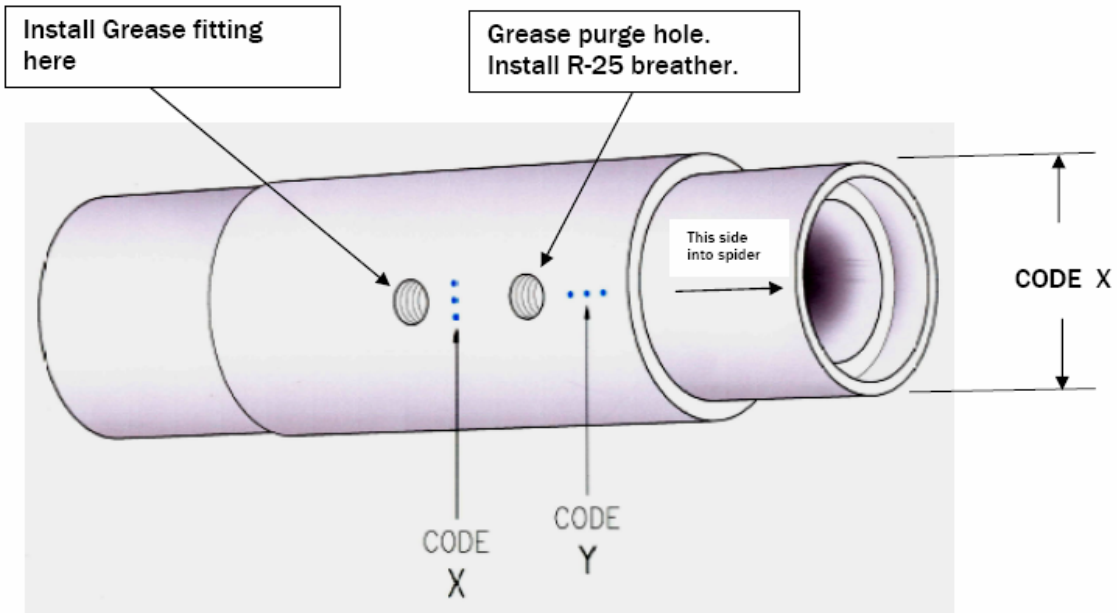

Fig. 1

Code X	* = Standard spider channel
	** = 1st oversize (SPIDER +)
	*** = 2nd oversize (SPIDER +)
Code Y	*, **, *** = Cam matching code
	see dots on end of cam are matched with the tube

THIC-15 series cam tubes come with matching cams in the box. Recognition marks are present for identification.

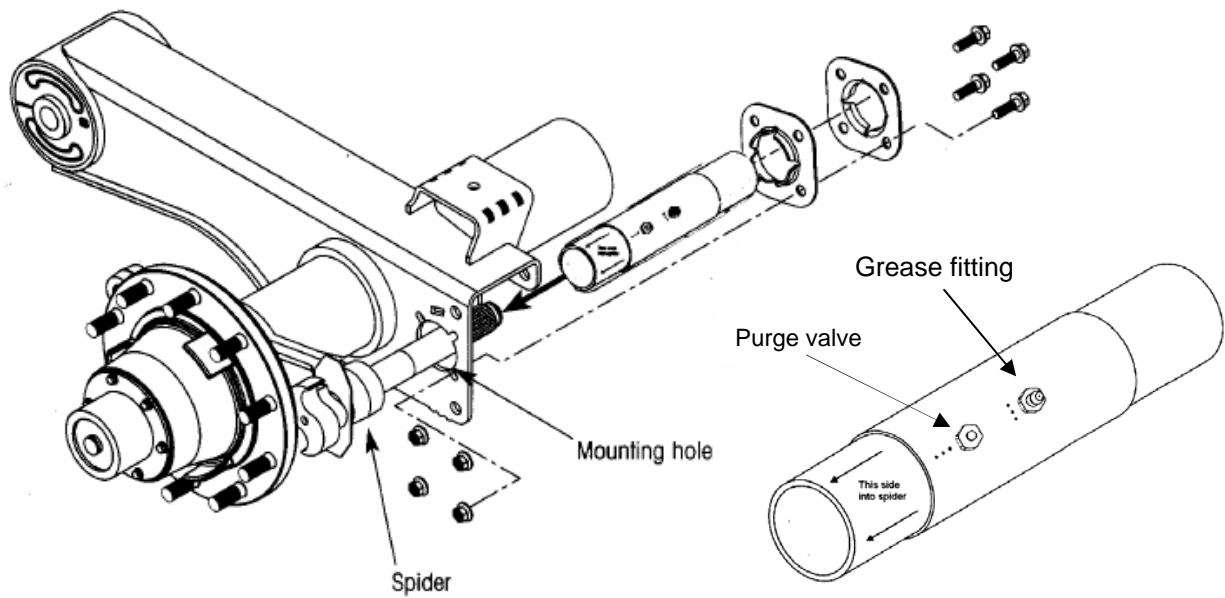

Fig. 2

THI 1500 series tube enclosures need to be press-fitted into the spider bracket channel. This press-fit is essential for the tube to be securely adapted to the spider bracket and to prevent damage inside the spider channel.

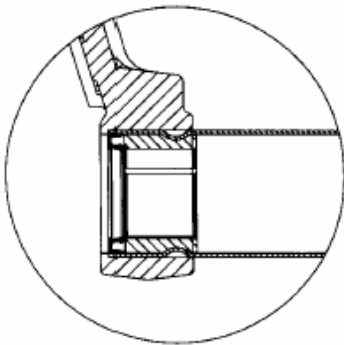

Fig. 3

Be sure to insert the extremity of the tube that is closest to the purge breather as described in fig. 1 & 2. This process is achieved by using a puller to insert the tube into the spider channel's bore until fully seated. Fig. 3

It is preferable to remove the wheel hub to perform this procedure easily and accurately. This replacement tube is intended to last many years and any rust damage or wear of the spider channels or to slack adjuster end bracket housing mounting hole must be dealt with before installation may resume. Take special care to rust proof your foundation parts prior to reassembly.

The puller kit shown below is specially designed for this tube installation, but any equivalent version of this tool can do the job as long as it can withstand the pull.

Tube Driver Kit # TDK-12250

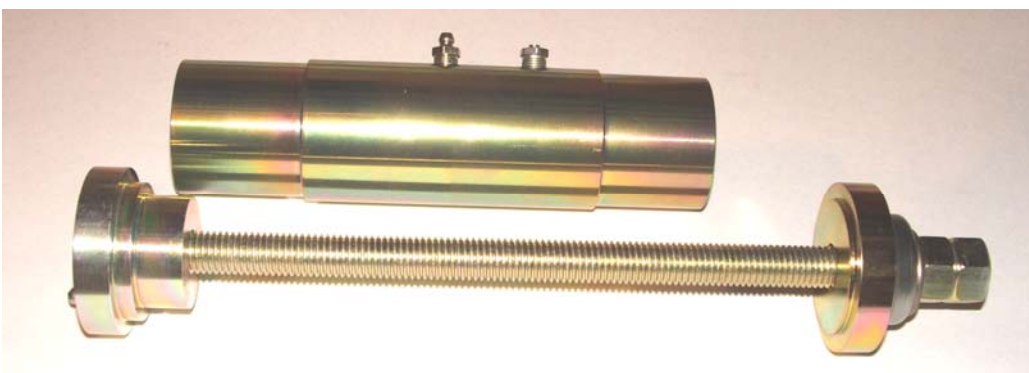

Fig. 4

Unique lubrication features

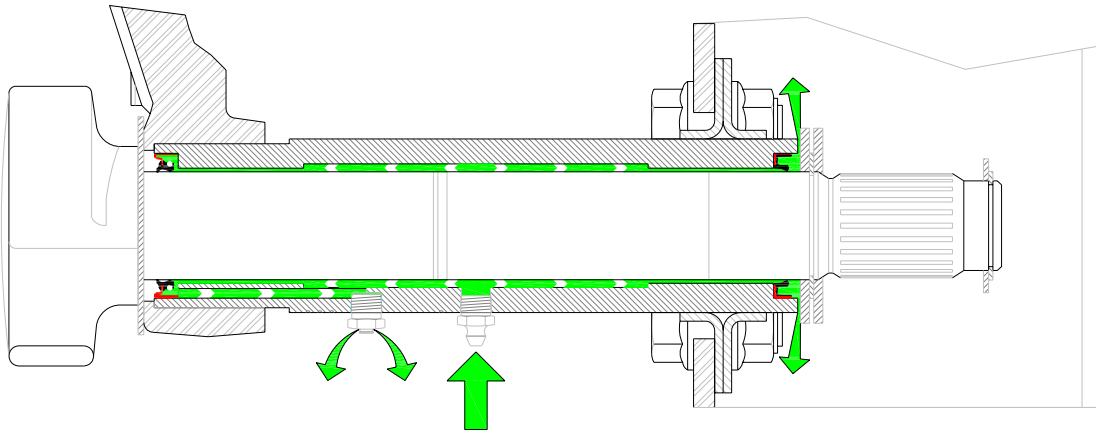

Fig. 5

The THI-1500 series tube feature a lubricant purge system that allows proper lubricant flow to the spider cam bearing journals whenever lubricating the assembly. This ensures proper lubrication of both cam bearing journals.

Conventional tube enclosure

Conventional cam-tube assemblies usually have new lubricant flowing to the spline end journal due to a positive seal at the spider end of the tube to prevent grease contamination of the brake foundation. This positive seal locks out new lubricant to be delivered to the spider bearing journal because the old lubricant cannot be purged out of the assembly.

Installing the Cam Tube



Clean the spider bracket and remove any rust from the Cam-tube channel.



Inspect the brake spider for external damage as well as internal tube channel integrity. Any damage in the tube channel is unacceptable for this type of repair. If there is any damage you must rebuild the unit or replace it.

Refer to fig. 6 for channel dimensions.

For an easy rebuilding procedure use the SPIDER + system

Contact us on the tech support line 1-877-765-9629

Measurements for cam-tube channels

Size of camshafts used on axles	Dimensions of tube channels
1-1/2" inch diameter	2.125" +/- .001"

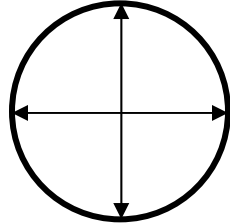

Be sure to take measurements both horizontally and vertically when checking tube channels integrity.

Fig. 6

This procedure doesn't change whether you are using a standard or oversize tube. The tube needs to be inserted at 5 – 15 ton pressure to ensure proper assembly.

Once all components are clean and dry, apply a thin film of lubricant to the spider channel's bore and onto the mating surface of the cam tube to be inserted.

Step 1. Line up the tube to the channel and introduce the tube to the spider.

Step 2. Align grease fitting to allow easy access (fig. 7)

Step 3. Using tool # TDK-12250 (see fig. 4) or a suitable equivalent puller, install the puller to press fit the tube into the spider channel and align. Tighten the puller assembly until the tube is fully seated.

Step 4. Clean the inside of the tube and lubricate lightly both bearing journals in the tube and the double lip seal at the brake side of the tube with grease.

Step 5. Insert the cam and rotate the cam to make sure it spins freely.

Step 6. assemble holding plates onto the tube and in the suspension beam's hole pattern. Tighten bolts to 35-45 ft.lbs (48 – 61 Nm).

If unable to align holding brackets with hole pattern in suspension beam refer to page 6.

Step 7. Reassemble all brake components as recommended by Hendrickson, except keep the brake adjusters for last item to assemble. Refer to service bulletin SBOC-113A for complete installation procedure for brake adjusters.

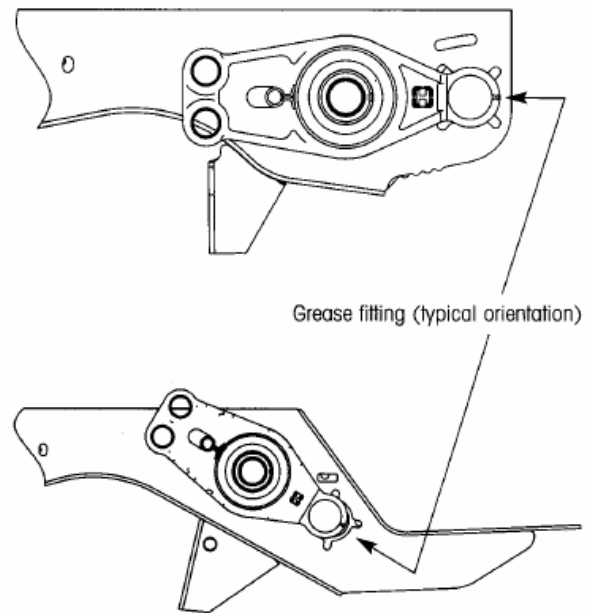
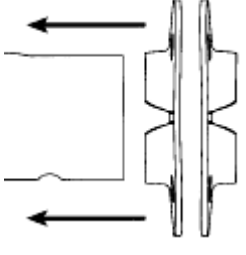
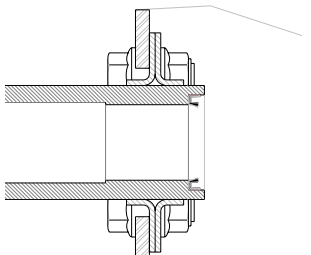

Fig. 7

Step by step installation procedure

	<p>Step 1. Line up the tube to the channel and introduce the tube to the spider.</p>	
	<p>Step 2. Align grease fitting to allow easy access (fig. 7)</p>	
	<p>Step 3. Using tool # TDK-12250 (see fig. 4) or a suitable equivalent puller, install the puller to press fit the tube into the spider channel and align. Tighten the puller assembly until the tube is fully seated.</p>	
	<p>Step 4. Follow steps 3 through 7 of the "Optimum Contact" cam-bushing installation procedure described in shop manual # SMCO-TA-1.2 or SMCO-DA-1.0. Clean the inside of the tube and lubricate lightly both bearing journals in the tube and the double lip seal at the brake side of the tube with grease.</p>	
	<p>Step 5. Insert the cam and rotate the cam to make sure it spins freely.</p>	
		<p>Step 6. Assemble holding plates onto the tube and in the suspension beam's hole pattern. Tighten bolts to 35-45 ft.lbs (48 - 61 Nm)</p>

If unable to align holding brackets with hole pattern in suspension beam refer to "SPIDER BRACKET ALIGNMENT" section on page 7.

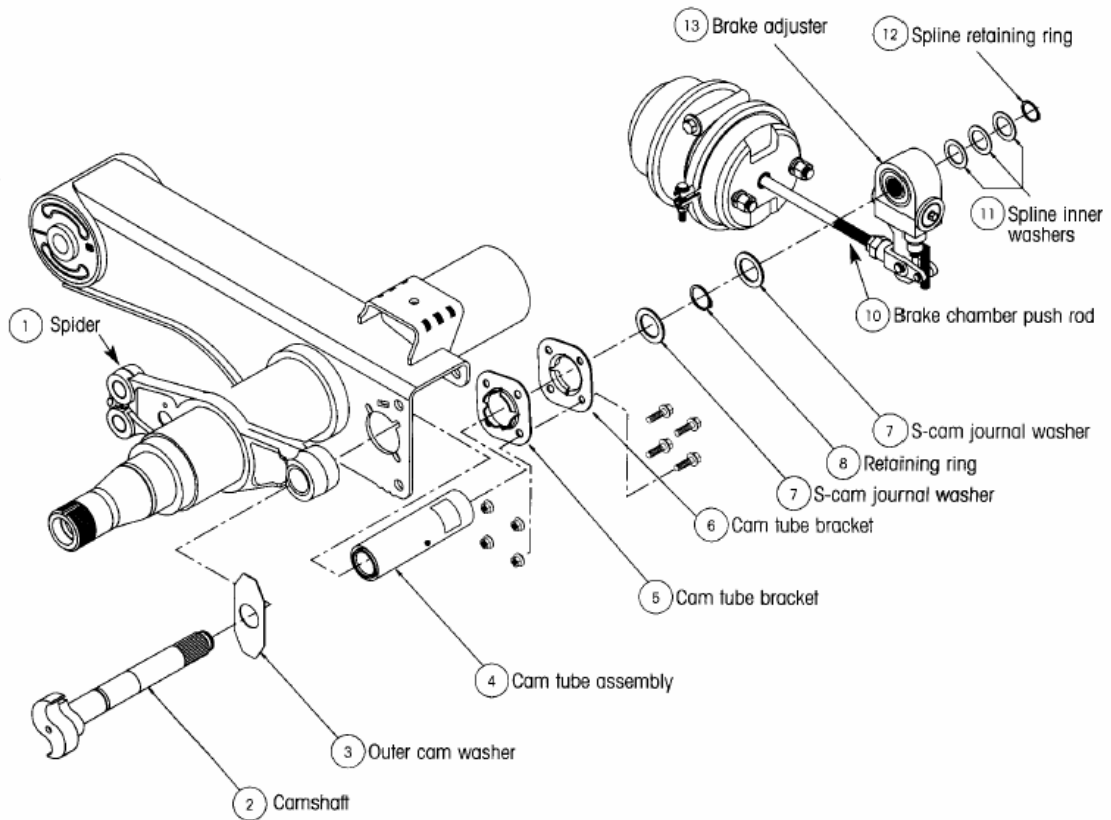

Fig. 9

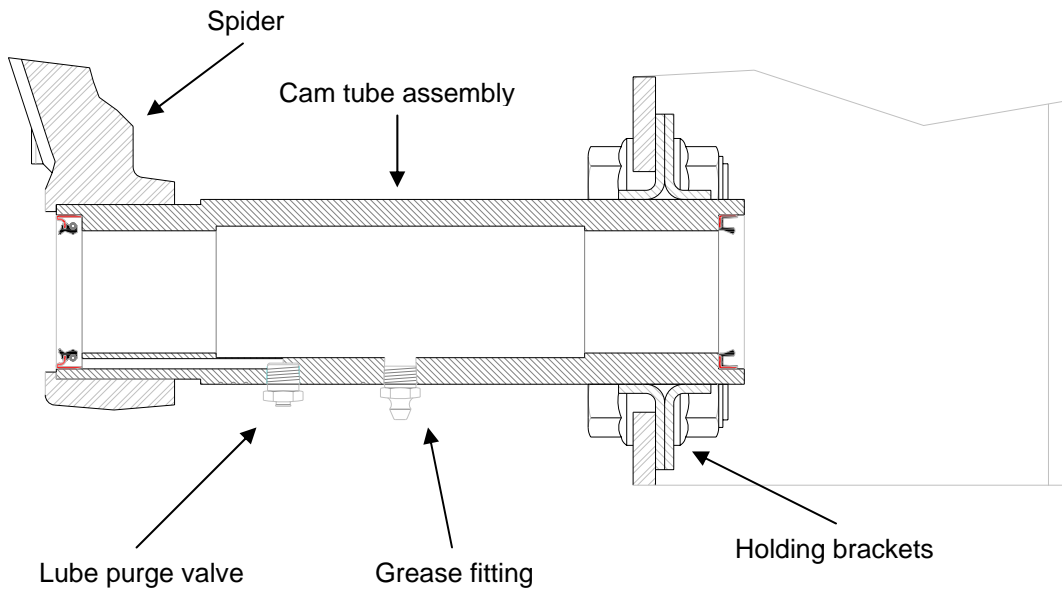

Fig. 10

This Cam Tube is designed to last longer than conventional replacement parts and special precautions are to be taken.

Brake adjuster spline gear mounting to the cam spline

It may be necessary to remove the brake adjuster from the cam spline after many years of service, and to do that without damage to the cam splines requires special attention when assembling the brake adjuster. Please see service bulletin **SBOC 113A** for complete installation procedure.

Spider bracket alignment

If tube does not align with center of suspension beam's hole pattern

- Check for proper installation of the tube within the spider bracket's bore.
- Check for spider bracket alignment and repair adequately.

Spider bracket tube channel damage

If spider channel is damaged and a standard tube can be inserted without at least 5 ton pressure, we recommend that you repair the channel or oversize it.

The THI-1500 series tube offers two oversize versions to repair your spiders and save your axles, with machine shop like quality results at reasonable cost.

Ask your tube supplier about **SPIDER +** or call the number below, and find out how you can do this repair “right on the spot” in your own shop, at a fraction of the cost to replace the axle.

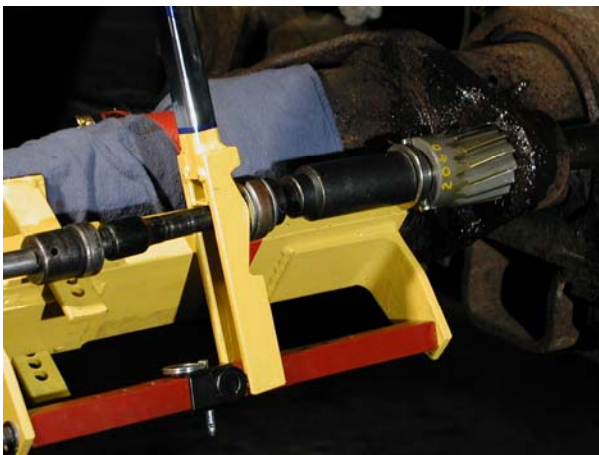

DO-IT-YOURSELF tool kit allows you to perform this easy procedure right in your shop, on the spot when you need it.

- Professional Machine shop quality results every time
- 30 minute procedure
- complete easy to follow instructions

" Optimum Contact " align boring procedure

For the "Optimum Contact" align boring procedure follow steps 3 through 7 of the "Optimum Contact" cam-bushing installation procedure described in our Trailer Axle shop manual # [SMCO-TA-1.2](#) or Drive axle shop manual # [SMCO-DA-1.0](#).

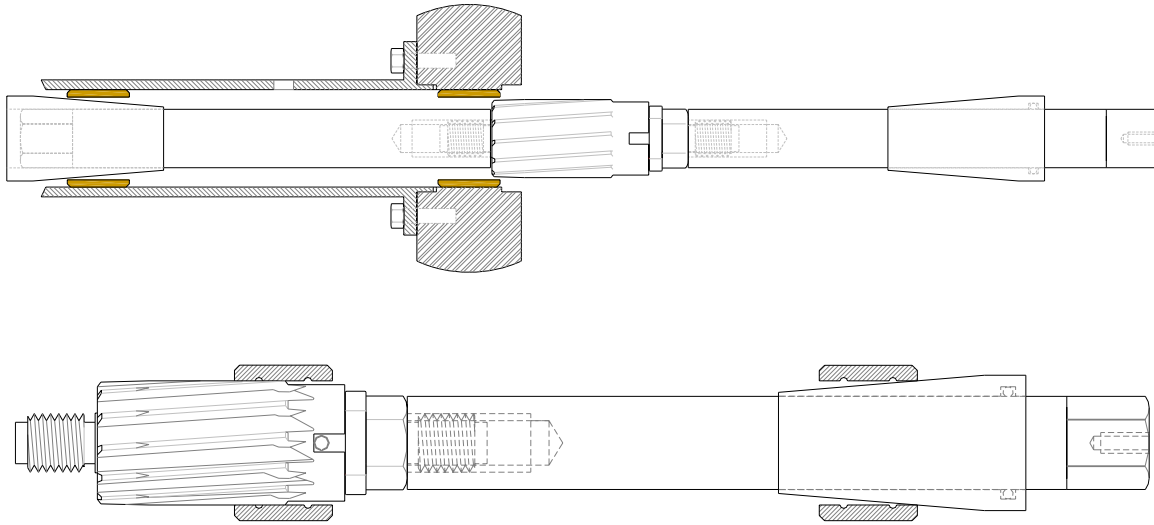

Maintenance

Inspect regularly as any other wheel component.

Lubricant grade requirements may vary with applications.

Summer highway driving ; #2 non-EP / #0 non-EP

Winter highway driving ; #0 non-EP

See service bulletin [SBOC-117](#) for more information on lubrication.

For any questions regarding this service bulletin please use
our toll free tech support line;

1 - 877-765 -9629